

Name: _____ Date: _____ Event: _____ Track: _____

Track Conditions

<input type="checkbox"/> Indoor	<input type="checkbox"/> Tight	<input type="checkbox"/> Smooth	<input type="checkbox"/> Hard Packed	<input type="checkbox"/> Blue Groove	<input type="checkbox"/> Wet	<input type="checkbox"/> Low Bite	<input type="checkbox"/> High Bite
<input type="checkbox"/> Outdoor	<input type="checkbox"/> Open	<input type="checkbox"/> Rough	<input type="checkbox"/> Loose/Loamy	<input type="checkbox"/> Dry	<input type="checkbox"/> Dusty	<input type="checkbox"/> Med Bite	<input type="checkbox"/> Other

Front Suspension

Ride Ht	_____
Camber	_____
Toe	_____
Sway Bar	_____
Notes:	_____

- 0mm
- 1mm
- 2mm

- 2mm
- 3mm
- 4mm

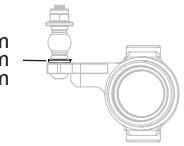

- PI
- AI
- 17.5
- 20

- 1mm
- 2mm

- Incline
- STD

Steering Arm

- A
- B

- 3
- 2
- 1

- 5
- 4
- 3
- 2
- 1

- 4
- 3
- 2
- 1

- Outside
- Inside

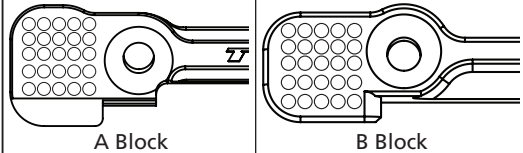

A Block

B Block

Rear Suspension

Ride Ht	_____
Camber	_____
Sway Bar	_____
Notes:	_____

- C
- B
- A

- 5
- 4
- 3
- 2
- 1

- 4
- 3
- 2
- 1

- STD
- +1mm
- +2mm

- Inside
- Middle
- Outside

- 0
- 1
- 2
- 3
- 4

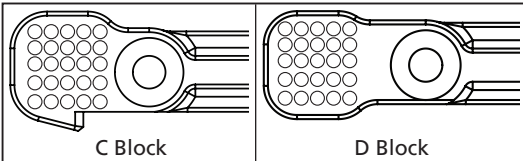

C Block

D Block

Chassis

Differentials

	Front	Center	Rear
Fluid	_____	_____	_____
Pins	<input type="checkbox"/> AL <input type="checkbox"/> STL	<input type="checkbox"/> AL <input type="checkbox"/> STL	<input type="checkbox"/> AL <input type="checkbox"/> STL
Case	<input type="checkbox"/> STD <input type="checkbox"/> HD	<input type="checkbox"/> STD <input type="checkbox"/> HD	<input type="checkbox"/> STD <input type="checkbox"/> HD

Shocks

	Front	Rear
Shock Type	<input type="checkbox"/> Bladder <input type="checkbox"/> Re Bladder <input type="checkbox"/> Emulsion <input type="checkbox"/> Vented	<input type="checkbox"/> Bladder <input type="checkbox"/> Re Bladder <input type="checkbox"/> Emulsion <input type="checkbox"/> Vented
Shaft Dia	<input type="checkbox"/> 3.5 <input type="checkbox"/> 4.0	<input type="checkbox"/> 3.5 <input type="checkbox"/> 4.0
Piston	_____	_____
Oil	_____	_____
Spring	_____	_____
Stroke	_____	_____
Droop	_____	_____

Tires

	Front	Rear
Brand	_____	_____
Tread	_____	_____
Compound	_____	_____
Insert	_____	_____
Sauce	_____	_____

Wing

Brand _____

Wicker Bill

- None
- Composite
- Carbon

- Composite
- Aluminum

- Composite
- Carbon
- Aluminum

- Ft Screw
- Rr Screw

- None
- Composite

Wing

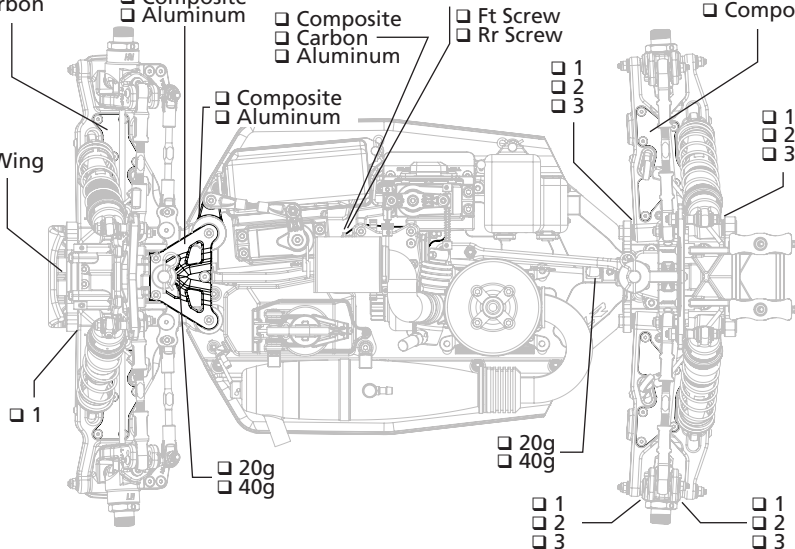

- 1
- 2
- 3

- 1
- 2
- 3

- 20g
- 40g

- 20g
- 40g

- 1
- 2
- 3

- 1
- 2
- 3